

HG4S-B Polisher/Buffer

The finishing touch



Polishing wheels



Dresser assembly

PRIMEEdge®
COZZINI CUTTING EDGES
AND SHARPENING SOLUTIONS

HG4S-B Polisher/Buffer

- Polishes and removes grinding marks from both sides of a blade simultaneously in a matter of seconds.
- Polishes blades up to 10" (254mm) long.
- Smooth blade edges can increase productivity by reducing knife drag through product, making cutting easier and increasing production.
- CE approved.

HG4S-B Polisher/Buffer

A complementary unit to the Twins or to any **PRIME**Edge sharpening system, the HG4S-B Polisher/Buffer delivers a smooth and polished edge on each blade.

The 4" (102mm) diameter buffing wheels eliminate grinding marks and produce a smooth, polished surface on knives up to 10" long. In a meat processing line, polished knife edges increase productivity by reducing blade friction and operator elbow/wrist fatigue.

The Polisher/Buffer consists of a cast aluminum body housed under a durable, easy-to-clean, fiberglass cover. The ergonomic design of the Polisher/Buffer provides operator comfort and safety. An adjustable, pivoting lamp can be oriented in different positions for excellent visibility while sharpening blades. Cart is included.

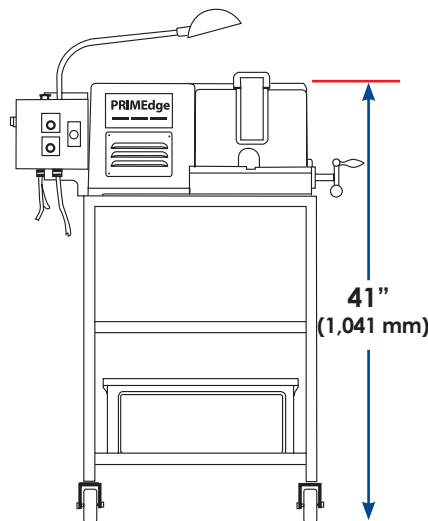
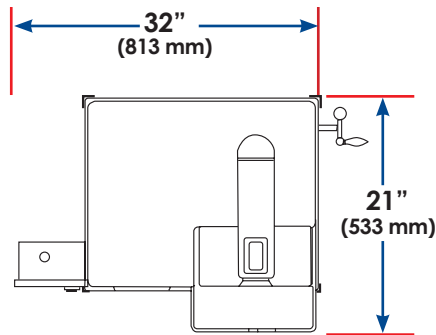

HG4S-B Polisher/Buffer			
Voltage	Frequency	HP	kW
115V	50 or 60 Hz	.5	.37
220V			

PRIMEEdge®
COZZINI CUTTING EDGES
AND SHARPENING SOLUTIONS

877-322-EDGE(3343) • primedge.com • sales@primedge.com • Fax:224-265-6638

PRIMEEdge, Inc. • Cutting Edges • Knife Sharpening Systems • Edge Maintenance Tools • Professional Sharpening Services
Circular Blade & Grinder Plate Sharpeners • Grinder Plates, Knives & Accessories • Sanitizer/Bacteria Reduction Washing Systems